

City of Cincinnati
Neighborhood Business District Improvement Program

CLIFTON HEIGHTS
Business District Benches

\$35,927.76
(MAJOR PROJECT)

April 21st, 2017

CITY OF CINCINNATI NBDIP FUNDING REQUEST APPLICATION

Each Neighborhood Business District may submit two project requests (one major and one minor or two minor). Complete each section and provide written documentation to receive credit on scoring.

Project Name: Business District Benches

Project Address: Calhoun & W McMillan between Clifton Ave & Vine St. (See Attachment C)

Amount Requested: \$35,927.76 (Major)

Neighborhood: Clifton Heights Empowerment Zone: YES Census Tract: 26

Business Association: Clifton Heights Business Assoc.

Community Council: CUF Neighborhood Assoc.

Project Description:

Our proposal is to purchase and install 16 benches in the Clifton Heights Business District. In some cases, these benches would be replacing advertising benches that were made illegal in the last few years. These benches served a valuable role as they provided relief to Metro riders; however, they were unsightly and negatively contributed to the perception of the area. Last Fall, the City began enforcing the law against advertising in the right-of-way, but there was no plan in place to accommodate the still existing need for benches.

When we first began exploring the need for benches in the business district, we had a fairly simple plan of using uniform 6 foot long benches. This was in large part due to the limited sidewalk right-of-way. After meeting with one of our partners, Hughes High School, we realized we had an opportunity to do something that was not only more functional, but unique. As a citywide STEM high school, almost 90% of Hughes' students rely heavily on busses to get to and from school. Their need for additional seating accommodations was apparent.

The advantage that Hughes possessed versus the rest of the business district was their ample setbacks gave us the space necessary to accommodate more seating and a fresh perspective. What we settled on after consulting with Hughes, the Business Association and the University of Cincinnati were 2 sculptural benches approximately 10 feet in circumference each that would be located at the two most active corners of the school. These benches would be aesthetically pleasing as well as more functional. In addition, Hughes has been looking at opportunities to reinforce their CORE values of Courage, Respect, Empathy, Desire, Integrity, and Teamwork. Consequently, these CORE values will be etched into the benches.

An important question to ask is what is the basis for this request and is it a part of a larger plan? In short, yes. The 2001 Clifton Heights / UC Joint Urban Renewal Plan provides the guidelines and framework for all of the proposals submitted as part of the overall Business District revitalization. The Clifton Heights Community Urban Redevelopment Corporation (CHCURC) is in the midst of implementing a series of developments that are outlined in the Plan. Our proposal seeks to complement these efforts as well as past CNBDU funded façade, gateway, and streetscape projects which have dramatically improved the aesthetic appearance of the Clifton Heights Business District and were also specifically identified in the Plan. This proposal specifically addresses elements of the Plan as can be seen in the following excerpts:

- “Emphasize pedestrian circulation along storefronts and intersecting blocks. Cleaner, well paved sidewalks, improved lighting, denser planting, and street amenities – maintained through a maintenance program.” (Page 6)
- “Develop a prototype or select a pre-manufactured metal street bench that would occur throughout the business area.... In conjunction with recommendations for planting and outdoor seating, it is suggested that bus shelters (and bus stops) and future shuttle stops be prime targets for improvement as mini-centers of urban sociability and public amenity.” (Page 21)

1. Type of Project: Major X Minor _____

2 & 3. NBD & Job Impact:

It is extremely difficult to calculate any jobs that might be created by this project as its goal is to improve the pedestrian environment and create a more inviting and enjoyable experience for the resident, student and customer. That said, it is very safe to state that the placement of benches will undoubtedly positively impact all the businesses in the area as well as the more than 3,500 bus riders that board and exit per day in our business district. Currently, there are approximately 100 businesses in Clifton Heights. All of these businesses, whether they be corporate or small business, goods or services, new or existing, will stand to benefit from this investment. Based on conversations with business owners and estimates where necessary, there are approximately 469 FTEs in Old Town, 132 in University Park, 478 in USquare, and another 230 FTEs associated with the Gateway to Uptown development. That is 1,309 FTEs that will be impacted by this investment.

In addition, it is important to note with this investment how the benches serve an even larger population. Eight different bus routes come to and through the Clifton Heights Business District. 3,500 people either board or exit a bus in our business district per day. The current facilities do not adequately serve this population. This project is an important step towards improving that dynamic and further encouraging alternate means of transportation.

4. Degree to which the project leverages private and other public funding.

<u>Fund Source</u>	<u>Private</u>	<u>Public</u>	<u>Amount</u>	<u>Use of Funds</u>
Classen Park		x	\$150,000	park renovations (complete)
Gateway West (Clifton Ave)		x	\$30,000	lighting, signage, landscaping (complete)
Façade Improvement Program		x	\$350,000	façade improvements (28 complete)
	x		\$650,000	
University Park Apts	x		\$65,000,000	mixed-use development (complete)
65 West	x		\$16,700,000	129 unit residential (complete)
University Square (Block 4)	x		\$78,000,000	mixed-use development (open Spring 2013)
Old Town Streetscape		x	\$1,390,000	streetscape (complete September 2012)
Fairfield Inn	x		\$10,000,000	114 bed hotel (open Fall 2016)
Old St George	x		\$14,000,000	50 bed boutique hotel (open Fall 2016)
The Verge	x		\$30,000,000	178 unit residential (open Fall 2016)

Gateway to Uptown (Block 1) x \$80,000,000 2 hotels (predevelopment)

5. Attach complete budget, including cost estimates, source of estimates, and contractor's bids
See Attachment B.

6. What is the neighborhood contribution to this project (including committed volunteer hours)?

The redevelopment corporation has partnered with the community council, business association, University of Cincinnati, and Hughes High School to ensure that this investment benefits as many people as possible. All of these organizations have been instrumental in selecting the benches, identifying the locations, and will be at the table as the project moves forward.

7. Does this project complete or continue a previously funded project? YES

If yes, please specify the following:

- a) Phased Project: N/A
- b) Cost over run: N/A
- c) Partial continuation of streetscape

8. Does your community have an approved plan? YES

If yes, which goal or objective of the plan does this project implement?

- "Emphasize pedestrian circulation along storefronts and intersecting blocks. Cleaner, well paved sidewalks, improved lighting, denser planting, and street amenities – maintained through a maintenance program." (Page 6)
- "Develop a prototype or select a pre-manufactured metal street bench that would occur throughout the business area.... In conjunction with recommendations for planting and outdoor seating, it is suggested that bus shelters (and bus stops) and future shuttle stops be prime targets for improvement as mini-centers of urban sociability and public amenity." (Page 21)

9. Letters from (See Attachment A):

- a) Clifton Heights Business Association
- b) CUF Neighborhood Association
- c) University of Cincinnati
- d) Uptown Consortium
- e) Hughes High School

10. Attach a map of the project location.

See Attachment C

11. Who is the Project Coordinator for this project?

Name: Matt Bourgeois
Address: 2510 Ohio Ave, Suite C Cincinnati, OH 45219
Phone: 513-564-0078 Fax: 513-564-0093 Email: matt.bourgeois@chcurc.org

List the names and phone numbers of active committee members who will be implementing this project.

This project has garnered the interest of a variety of stakeholders, all of whom we expect to continue to engage and seek input from.

Doug Barclay	678-6460	Clifton Heights Business Association – Barclay Real Estate Mgt
JD DuBois	200-9713	Clifton Heights Business Association – DuBois Book Store
Tom Erbeck	520-9188	Clifton Heights Business Association – Adriatico’s Pizza
Mary Beth McGrew	556-1933	University of Cincinnati Architect’s Office
Matt Bourgeois	564-0078	Clifton Heights Community Urban Redevelopment Corporation
Kathy Wright	363-7400	Hughes High School
Ted Meyer	632-7547	Metro

ATTACHMENT A

Support Letters

University of Cincinnati
Hughes STEM High School
Clifton Heights Business Association
CUF Neighborhood Association
Uptown Consortium



Division of Administration and Finance
Planning + Design + Construction
University of Cincinnati
PO Box 210186
Cincinnati, OH 45221-0186

University Hall, Suite 600
51 Goodman Drive
Cincinnati, OH 45219

Phone: (513) 556-1933
Facsimile: (513) 556-2216

April 3, 2017

Mr. Andrew Naab
Department of Community & Economic Development
City of Cincinnati
805 Central Avenue, Suite 700
Cincinnati, Ohio 45202

Dear Mr. Naab,

The University of Cincinnati is pleased to support the Clifton Heights Community Urban Redevelopment Corporation's efforts to secure funding for benches in the business district. As an urban campus, we pride ourselves on walkability and accessibility. This project will help continue our efforts to make campus and its adjacent neighborhoods more pedestrian friendly.

Thank you for your consideration and please let us know if there is anything further we can provide.

Sincerely,

A handwritten signature in cursive script that reads 'Mary Beth McGrew'.

Mary Beth McGrew
Sr. Associate Vice President of Planning + Design + Construction
University Architect

cc: Matt Bourgeois,
Clifton Heights Community
Urban Redevelopment Corporation



*2515 Clifton Ave.
Cincinnati, Ohio 45219
HughesSTEM.cps-k12.org*

April 19, 2017

Mr. Andrew Naab
Department of Community & Economic Development
City of Cincinnati
805 Central Avenue, Suite 700
Cincinnati, Ohio 45202

Dear Mr. Naab,

As Principal of Hughes High School, I am writing today to support the Clifton Heights Community Urban Redevelopment Corporation's (CHCURC) grant application for benches in the Clifton Heights business district.

Hughes has been a part of the Clifton Heights community for nearly a century. Over the last decade, our program has changed from a neighborhood school to a STEM program that attracts students from across the City of Cincinnati. This transition has provided many opportunities, but also challenges. Our school population is around 1,000 students and approximately 90% of those students rely on bus service.

The current Metro facilities are inadequate to service our students and we welcome the opportunity to work with CHCURC and the community to improve those conditions for not only our students, but the larger Uptown community as well.

Thank you for your consideration. If I can provide any further support, please let me know.

Sincerely,

A handwritten signature in black ink that reads "Kathy D. Wright".

Kathy Wright,
Principal

cc: Matt Bourgeois, CHCURC



Clifton Heights Business Association

March 15, 2017

Mr. Andrew Naab
Department of Community & Economic Development
City of Cincinnati
805 Central Avenue, Suite 700
Cincinnati, Ohio 45202

Dear Mr. Naab,

The Clifton Heights Business Association is pleased to support the Clifton Heights Community Urban Redevelopment Corporation's efforts to secure funding for benches in the business district. As a dense, urban neighborhood, it is imperative that we help make the pedestrian experience as welcoming as possible and facilitate transit ridership. This project accomplishes both of those goals.

Thank you for your consideration and please let us know if there is anything further we can provide.

Sincerely,

A handwritten signature in black ink, appearing to read "Tom Erbeck", written over a light blue horizontal line.

Tom Erbeck,
President

cc: Matt Bourgeois, CHCURC



NEIGHBORHOOD ASSOCIATION

representing Clifton Heights | University Heights | Fairview

April 6, 2017

Mr. Andrew Naab
Department of Community & Economic Development
City of Cincinnati
805 Central Avenue, Suite 700
Cincinnati, Ohio 45202

Dear Mr. Naab,

The CUF Neighborhood Association is pleased to support the Clifton Heights Community Urban Redevelopment Corporation's efforts to secure funding for benches in our business district. For many years, CUF has been dissatisfied with the advertising benches that were haphazardly strewn on our sidewalks. We are excited that this project will enable their removal and allow for more useable benches without unsightly advertisements. New benches will be welcomed by the many CUF residents who regularly use public transportation.

Thank you for your consideration, and please let us know if we can be of further assistance.

Sincerely,

Linda Ziegler, President
CUF Neighborhood Association

cc: Matt Bourgeois, CHCURC



UPTOWN CONSORTIUM, INC.

629 Oak Street
Suite 306
Cincinnati, OH 45206

office: 513.861.8726
fax: 513.861.1902

www.uptowncincinnati.com

April 3, 2017

Mr. Andrew Naab
Department of Community & Economic Development
City of Cincinnati
805 Central Avenue, Suite 700
Cincinnati, Ohio 45202

Dear Mr. Naab,

The Uptown Consortium is pleased to support the Clifton Heights Community Urban Redevelopment Corporation's efforts to secure funding for benches in the business district. One of our efforts has been to invest in and encourage multiple modes of transportation. As the Uptown grows, it is imperative that we give our residents, students, visitors, patients and others multiple ways of getting around Uptown and the City as a whole. By adding benches to the already improved streetscapes, we can help ensure that people have a positive experience with transit and with our vibrant business districts.

Thank you for your consideration. If I can provide any further support, please let me know.

Sincerely,

A handwritten signature in black ink, appearing to read "Beth Robinson".

Beth Robinson,
President & CEO

cc: Matt Bourgeois, CHCURC

ATTACHMENT B

Project Budget

DuMor 160 Bench (14 6' benches w/ middle arm rest)	\$15,260.00
"Custom" Clifton Heights Logo Treatment	\$5,320.00
Tectura Nest Bench (2)	\$10,661.53
<u>Contingency (15%)</u>	<u>\$4,686.23</u>
TOTAL	\$35,927.76

* See attached bid / spec sheets for greater detail.

Service Supply Ltd., Inc.

1610 Lancaster Ave
 Reynoldsburg, OH 43068
 Ohio: 800-282-1900
 WV & Indiana: 800-848-7556
 Local: 614-861-3681
 Fax: 614-863-0113

QUOTATION

Date	Quotation #
4/4/2017	4812

Project
REVISED QUOTE DUMOR BENCHES WITH LOGO PLAQUE CLIFTON HEIGHTS COMMUNITY CENTER

Customer
CLIFTON HTS COMMUNITY CENTER URBAN REDEVELOPMENT CORP MATTHEW P. BOURGEOIS, DIRECTOR 2510 OHIO AVE, SUITE C CINCINNATI OHIO 45219

Description	Qty	Unit Price	Total
DUMOR 160-60-3AR - 6' CAST BENCH, STEEL SEAT, 3 ARMS	14	1,090.00	15,260.00
DUMOR PLAQUE-Q89ZE - 5 1/2" X 7 3/4" X 3/8" OVAL ZINC ETCHED PLAQUE AS PER LOGO	14	380.00	5,320.00
AS YOUR SPECIAL DISCOUNT ALL FREIGHT & HANDLING CHARGES WILL BE PAID BY SERVICE SUPPLY LTD INC.			
NOTE: WE WILL HAVE TO HAVE A VERY HIGH RESOLUTION IMAGE OF THE LOGO TO SEND TO MANUFACTURER FOR THE PLAQUE			
QUOTATION VALID FOR 30 DAYS FROM ABOVE DATE AND SUBJECT TO REVIEW.			

NO TAXES ARE INCLUDED IN ABOVE PRICE. ADD TAX IF APPLICABLE.

Total	\$20,580.00
--------------	--------------------

UNION AND PREVAILING WAGES NOT APPLICABLE. FOR LIABILITY REASON. WHEN INSTALLATION IS QUOTED, SERVICE SUPPLY LTD., INC. IS REQUIRED TO USE FACTORY TRAINED INSTALLERS.

FOB: PREPAY & ADD

Delivery A.R.O.: 6-8 WEEKS

Payment Terms: NET 20 DAYS-APPROVED CREDIT

QUOTATION BY - ALAN KLETECKA, SALES MANAGER

Quotation typed by - LINDA GROVES

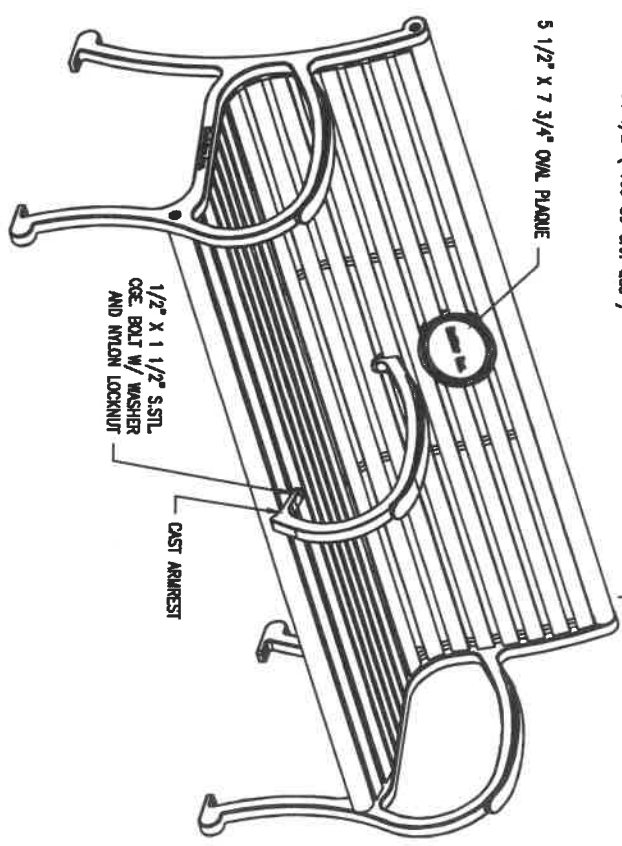
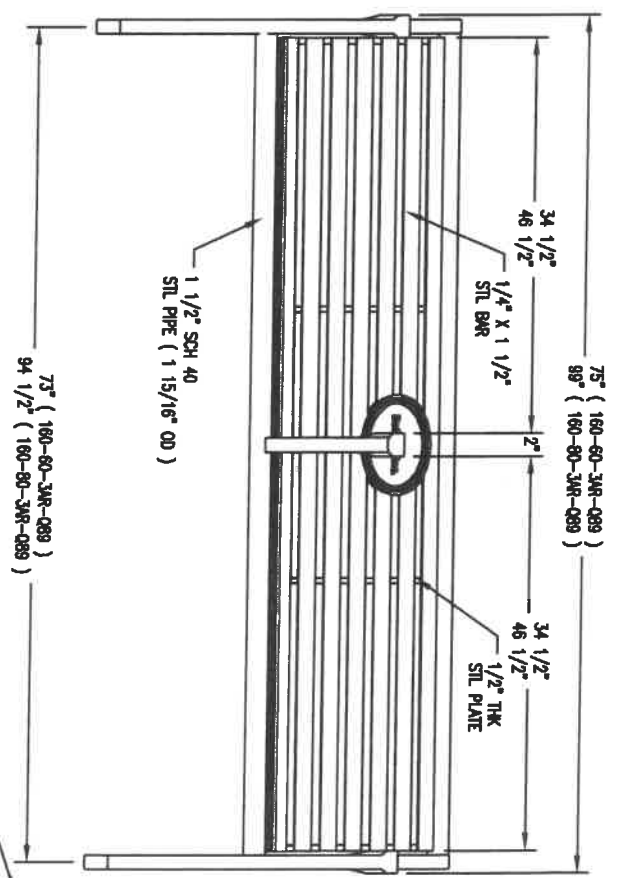
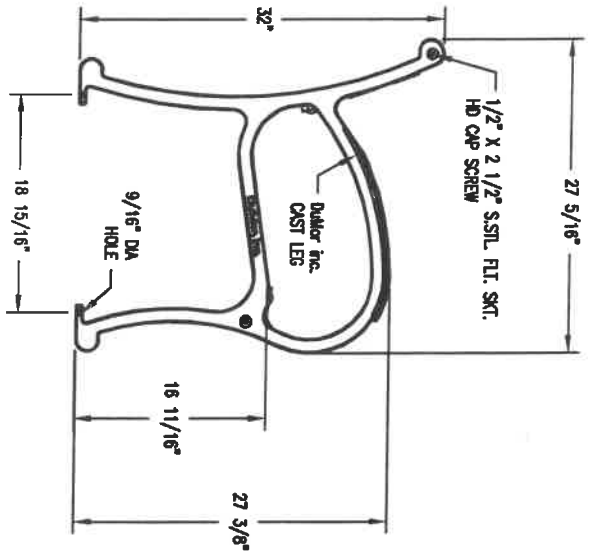

LENGTH OPTIONS

- 6' BENCH
- 8' BENCH

NOTES

- 1.) ALL STL. MEMBERS COATED W/ ZINC RICH COATING THEN POLYESTER POWDER COATED.
- 2.) 1/2" x 3 3/4" EXPANSION ANCHOR BOLTS PROVIDED.



BENCH

DATE DRAWN : 03/31/17
DRAWN BY : JESS
DATE REV. : 00/00/00
REV. BY : XXX

REV. A

DRAWING NUMBER FOR 5 1/2" X 7 3/4" OVAL PLAQUE

SHEET 1 OF 2

- NOTES:**
- 1.) DURING ASSEMBLY PROCEDURE, DO NOT COMPLETELY TIGHTEN HARDWARE.
 - 2.) THE ACTUAL PARTS WILL NOT BE NUMBERED. NUMBERS ONLY APPLY TO DRAWING.
 - 3.) UPON COMPLETION OF ASSEMBLY SQUARE ALL COMPONENTS THEN TIGHTEN ALL HARDWARE.
 - 4.) MOUNT AND ANCHOR AS SPECIFIED.

- TOOLS REQUIRED**
- 3/4" WRENCH
 - 5/16" ALLEN WRENCH
 - 1/2" MASONRY DRILL BIT
 - DRILL
 - RATCHET STRAP (PROVIDED)

- ① ATTACH SEAT TO SUPPORTS, LOCATE ARMREST ON SEAT AND ATTACH.

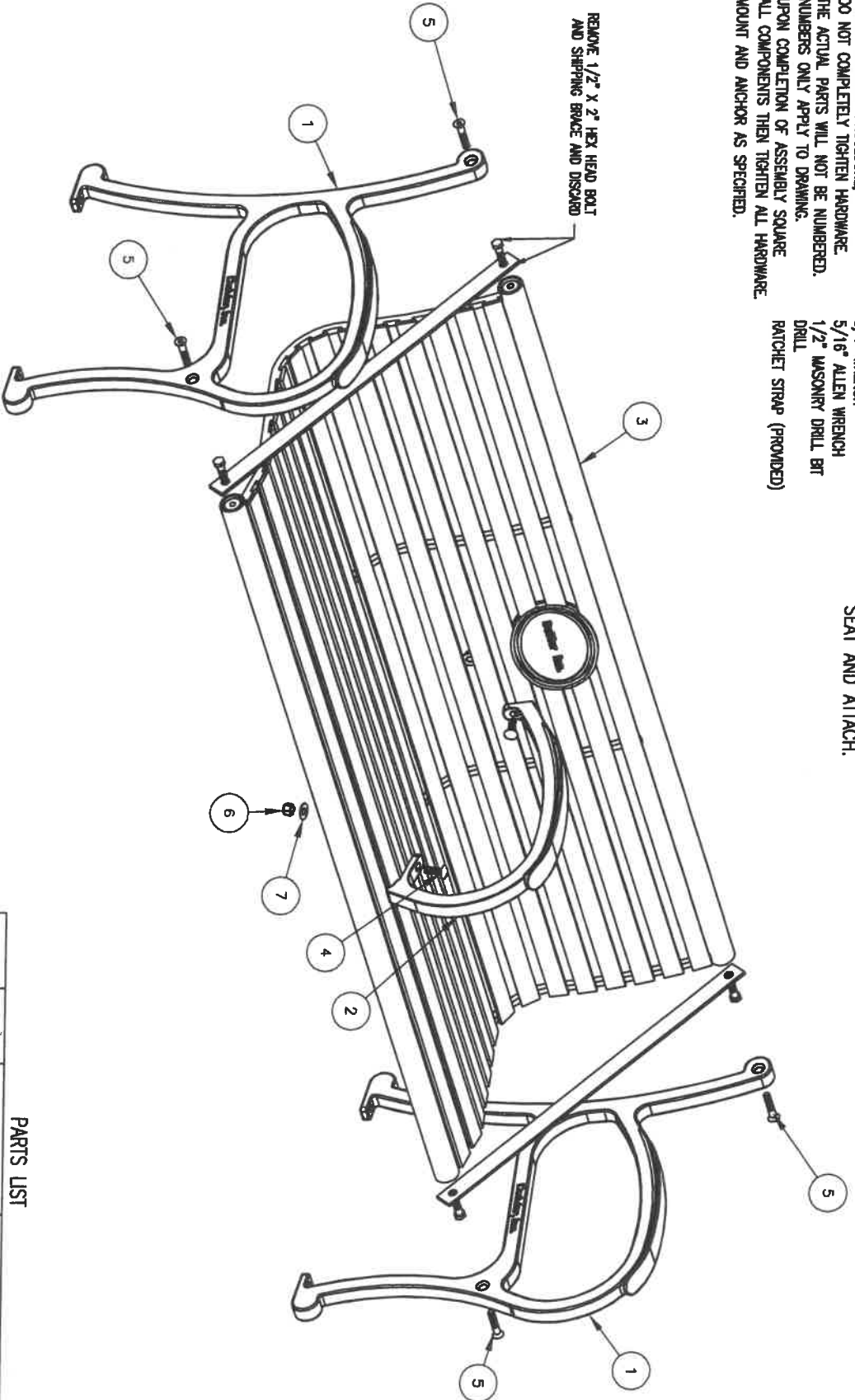

PARTS LIST

ITEM	QTY	PART NO	DESCRIPTION
8	1	K-ANCO880-4	1/2" X 3 3/4" SS ANCHOR KIT (4PC)
9	1	K-CO3024-2L	1/2" OSE BOLT HARDWARE KIT (2PC)
10	1	K-FCB840-4	1/2" CAP HARDWARE KIT (4 PCS)

ITEM	QTY	PART NO	DESCRIPTION
1	2	0-160-00-01	CAST IRON BENCH SUPPORT FOR BACKREST
2	1	0-160-00-03	CAST IRON ARM REST
3	1	0-160-60-089-02	6' STL SEAT FOR 5 1/2" X 7 3/4" OVAL PLAQUE
4	2	1-11-042	1/2" X 1 1/2" SS OSE BOLT
5	4	1-12-085	1/2" X 2 1/2" FLT SRT HD CAP SCR
8	2	1-20-015	1/2" SS NYLON LOCKWUT
7	2	1-22-015	1/2" SS FLAT WASHER

KITS REQUIRED

DUMOR, Inc.

ASSEMBLY INSTRUCTIONS

DATE DRAWN : 03/31/17
 DRAWN BY : ESS
 DATE REV. : 00/00/00
 REV. BY : XXX

REV. A

DRAWING NUMBER FOR 5 1/2" X 7 3/4" OVAL PLAQUE

160 SERIES-3AR-089

SHEET 2 OF 2



TECTURADESIGNS.COM

DIRECT: 715.359.3121
MAIN: 800.388.8728
MAILING: PO BOX 1520 | WAUSAU, WI 54402-1520
SHIPPING: 9001 BUSINESS HWY 51 | ROTHSCHILD, WI 54474



QUOTATION

Matt Bourgeois
Clifton Heights Community Urban Redevelopment Corp
2510 Ohio Ave Ste C
Cincinnati OH 45219

Date: 4/5/2017
Phone: (513) 910-5989
Fax:
Email: Matt.bourgeois@chcurc.org

PROJECT NAME: Bench Project
BID NUMBER:

IN COMPLIANCE WITH YOUR REQUEST FOR A PRICE QUOTATION ON SITE FURNISHINGS SUPPLIED BY WAUSAU TILE, WE SUBMIT THE FOLLOWING. IF THE PRODUCT QUANTITY OR PRODUCT DETAILS ARE DIFFERENT THAN THE SPECIFICATIONS LISTED BELOW, PLEASE ADVISE FOR A NEW PROPOSAL.

QTY	PRODUCT	DESCRIPTION	UNIT PRICE	TOTAL PRICE
2	DF5510	142" x 126" x 31" H Precast Concrete Nest Bench, Standard Finish/Colors., 10,230 Lbs	\$ 4,624.00	\$ 9,248.00



QUOTATION IN EFFECT FOR 30 DAYS FROM ISSUE DATE UNLESS OTHERWISE NOTED.

WE QUOTE YOU AS ABOVE F.O.B. DESTINATION: Cincinnati OH 45219

SHIPMENT CAN BE MADE IN: 6 Weeks

SUBTOTAL : \$ 9,248.00
SHIPPING : \$ 1,413.53
SALES TAX (IF APPLICABLE): \$ ~~746.34~~
TOTAL : \$ 11,407.84
\$10,661.53

TERMS & CONDITIONS:

1. This is a materials only bid valid for 30 days from date of bid. Prices are based on square footage or units as listed above, and subject to change if there are any increases or decreases of quantities to the project.
2. 30% down payment is required on all custom or modified products prior to start of production.
3. Field measurements, specifications and quantity confirmation are responsibilities of the customer.
4. Freight rates are based on today's rates and are valid for 30 days from bid. Delivery is for one location only unless noted in bid.
5. Customer will be notified when product is ready for delivery. Storage charges apply if customer delays shipment more than 30 days after notice.
6. All cancelled /returned orders must receive prior approval from a sales representative.
7. Both installation and assembly are the responsibility of the customer or its consignee.
8. Materials must be unloaded within 2 hours of arrival or customer will be charged for hold-over at the rate of \$100/hour.
9. Wausau Tile standard purchase and warranty terms apply as stated under Terms of Sale on Wausau Tile's Website
10. Sales or use tax is customer's responsibility and due as part of the payment to Wausau Tile before shipping occurs unless a properly executed tax exempt certificate is provided to Wausau Tile. Deliver the tax exempt certificate by fax to 715-355-4627 or provide an original by mail if required by state law.
11. Federal Contracting Compliance and CA Transparency in Supply Chains Act is available on Wausau Tile's Website.

PURCHASING CONDITIONS:

1. The purchase order and payment should be made out to Wausau Tile.
2. To expedite shipment, please include an address for billing and an address for delivery.

Approved by:

TECTURA DESIGNS

Rachel Bathke

Product Information

Nest Bench DF5510

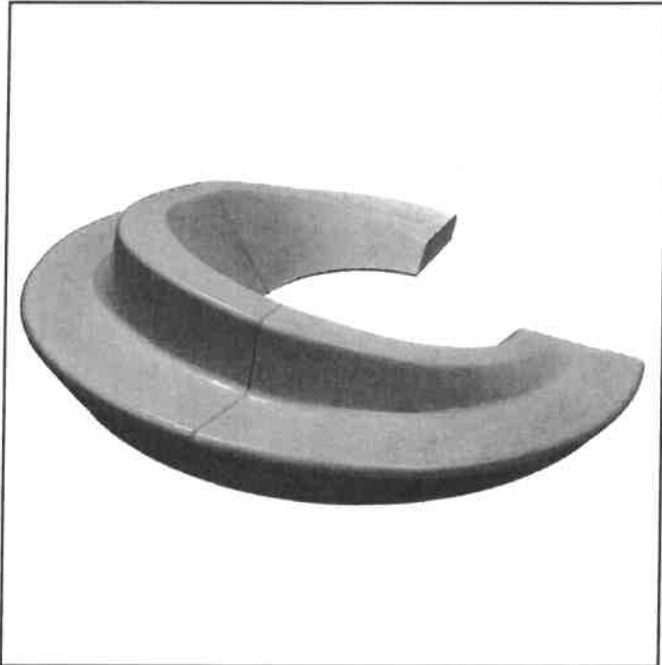

Size: 142" x 125 11/16" x 30 5/8"

Weight: 10,230 lbs.

Material: Reinforced Concrete

Reinforcing: Steel Rebar

Parts: (3) Pieces to Per Bench

Features: Lifting Strap Slots Cast in Each Piece

Concrete Finish Options

- Standard Color Palette

TECTURA
designs

A WAUSAU TILE INC. BRAND

PO Box 1520, Wausau, WI 54402-1520
(800 388-8728)

Email: wtile@wausautile.com
Web: wausautile.com

Date: 3/2017